

Junior Users Manual



Intruder Junior
Inspector Nick Junior



SUBTECH VISION TECHNOLOGY
DESIGN & MANUFACTURING INC.
For Over 30 Years



WARNING



WARNING

- Do not modify the unit
- Do not use in explosive atmospheres

CAUTION

- Keep out of reach of children
- Do not look directly into the camera, serious eye damage may occur
- Do not forcibly bend the push rod or use to push objects
- Strong impact on the device may result in breakage of the lens (made of glass) or the push rod
- Do not store device at a temperature below -4° or higher than 140°
- Store in a dry ventilated area
- Keep the device away from acid or alkaline solutions, do not store near gas or oil products
- Do not remove the SD Card while data is being saved to the card, doing so may damage the data and the card
- Turn off the unit after each use, leaving the unit on will drain the battery
- Leaving the WIFI on WILL drain the battery fast
- For best results use the AUTO OFF function to preserve battery life

TABLE OF CONTENTS

Topic	PAGE
Warning and Safety Information	2
Contents & Accessories	4
1. Description	5
2. Preparation For Use	6
3. Menu Setup	7
4. Video Output	9
5. Text Annotation	11
6. Digital Zoom	12
7. LED adjustment	12
8. Mirror/Reflecting object surface	12
9. Snapshot & Recording	12
10. File Mode	13
11. Photo Compare	14
12. Transferring photos & Videos to PC	14
13. Troubleshooting Display Issues	15
14. Technical specs for Display	16
15. Removal reel	17
16. Removal Hub from cart	18
17. Attach reel	19
18. Remove / Install Camera	20
19. Skid Installation	21
20. WIFI	22
21. Camera Locators	23
22. Unit Specifications	24
Warranty	25
Contact information	27

CONTENTS & ACCESSORIES

STANDARD EQUIPMENT

1. Display Unit
2. Cart
3. Reel w/ Hub
4. A /C Charger
5. Interface Cable
6. Self Leveling Camera
7. Skid
8. Hub

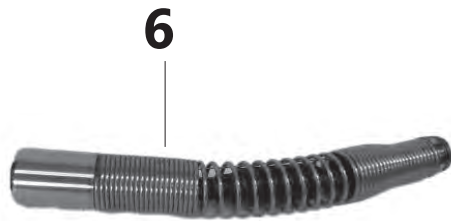

PLEASE RECORD YOUR SERIAL NUMBERS

DISPLAY
CAMERA
REEL

Location of serial numbers

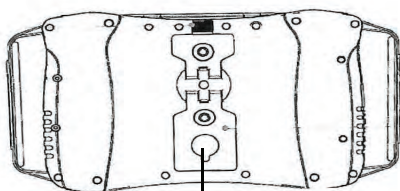

DISPLAY

CAMERA



REEL



1. DESCRIPTION

The Junior Display Unit allows the user to view the camera. The unit comes in a sturdy carry/protective case and consists of a wide angle TFT 7" LCD screen. The unit has the ability to view, store and review photos and videos. Images can be displayed directly onto a TV screen or stored and transferred to a PC. The display Unit is charged by LI-Polymer batteries, charger included.

18 V Milwaukee battery system option

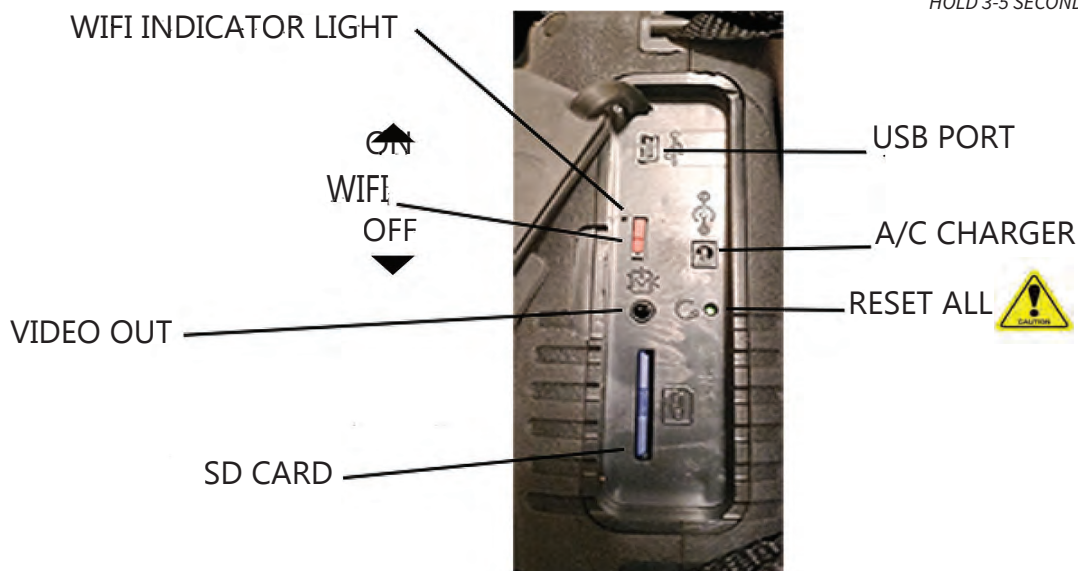
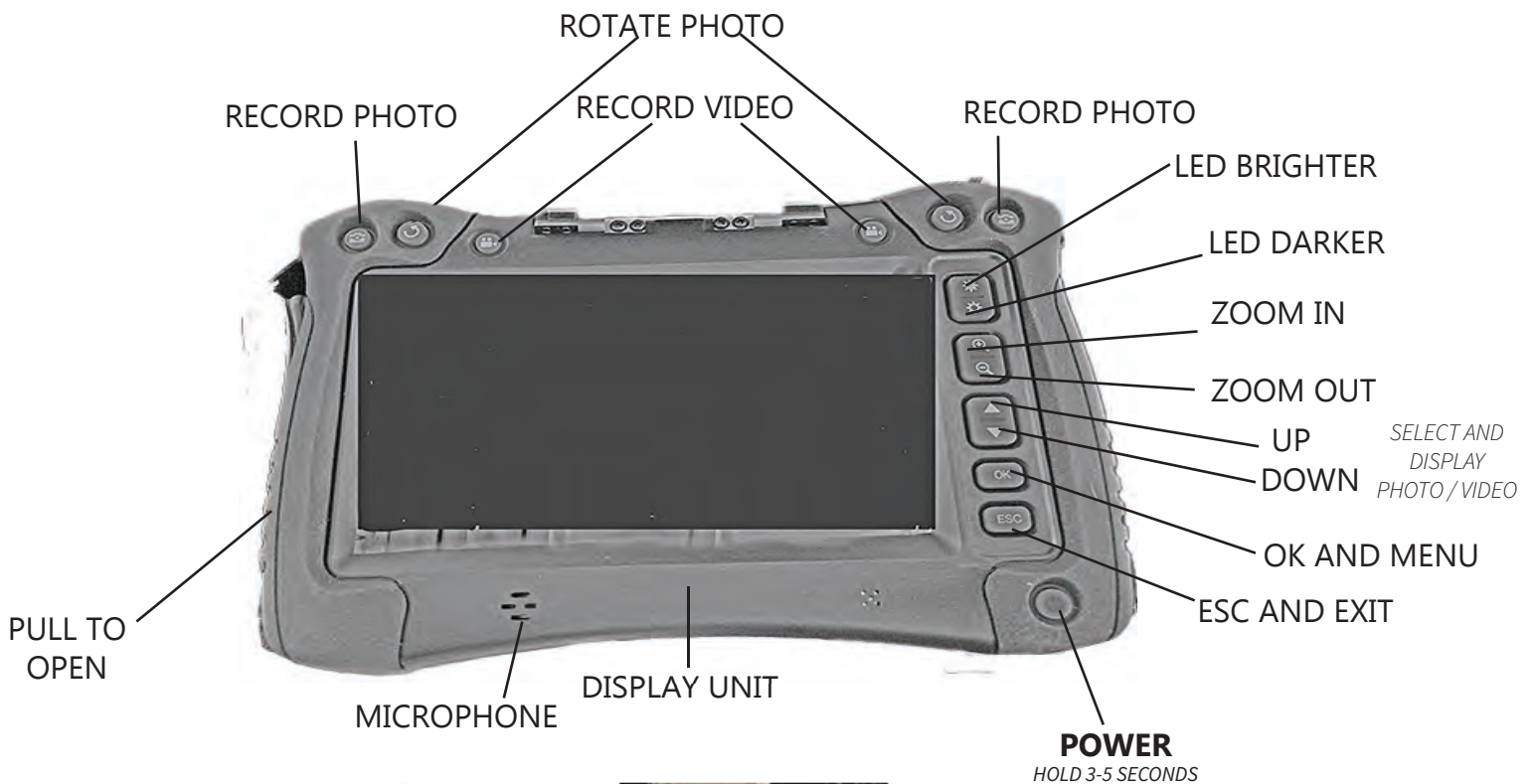

TURN OFF LCD TO CONSERVE BATTERY LIFE

2. PREPARATION FOR USE

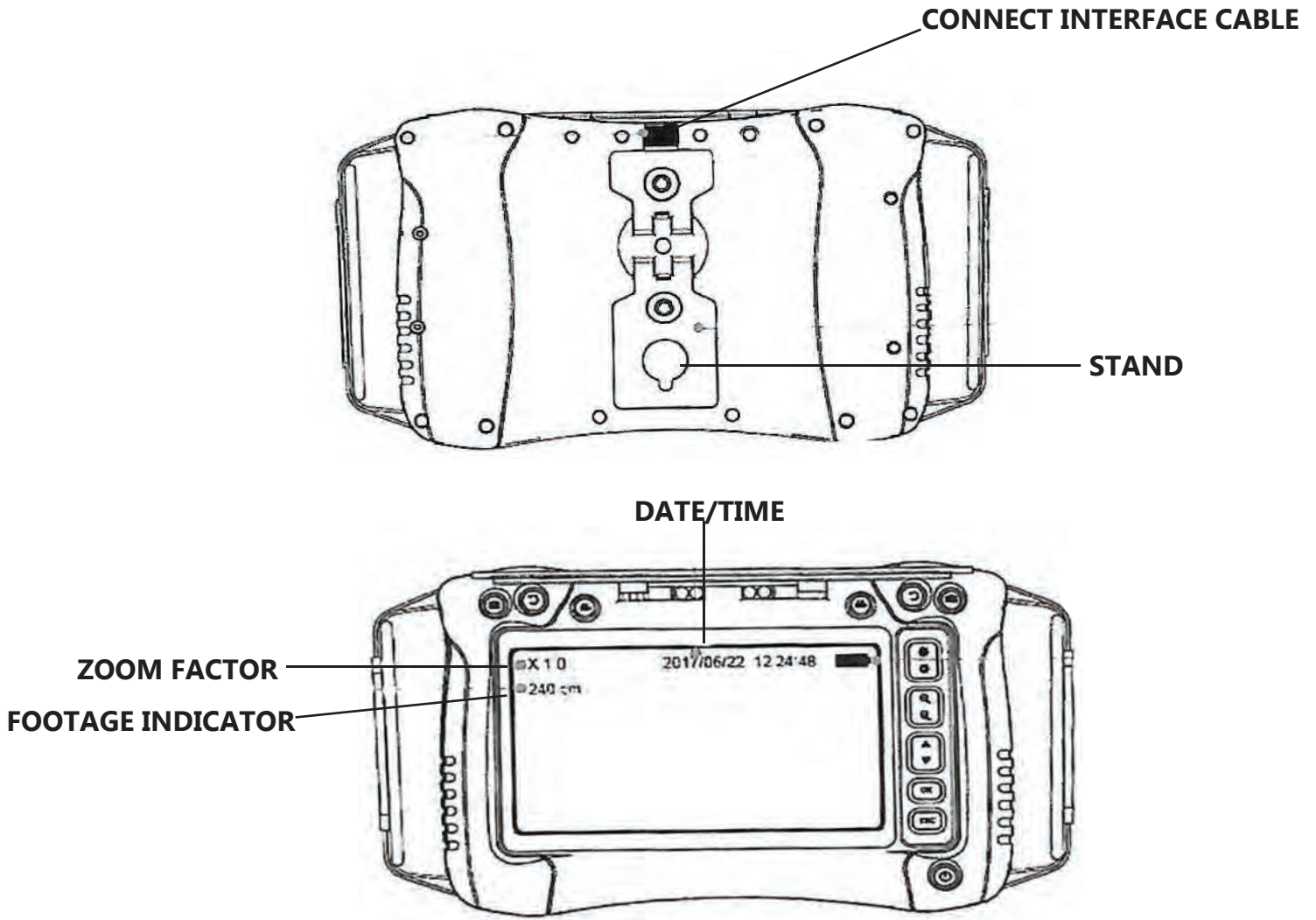

Before use insert SD card as shown in Fig. 1

Insert Interface Cable as shown in Fig. 2, align pins and tighten collar.



FIG. 1

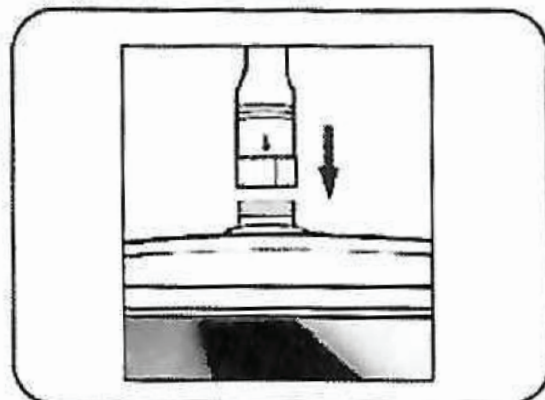

FIG. 2

Press the Power button for 3-5 seconds to turn the display unit on.

The start-up screen is shown briefly followed by the status screen for 5 seconds. **Fig 3**

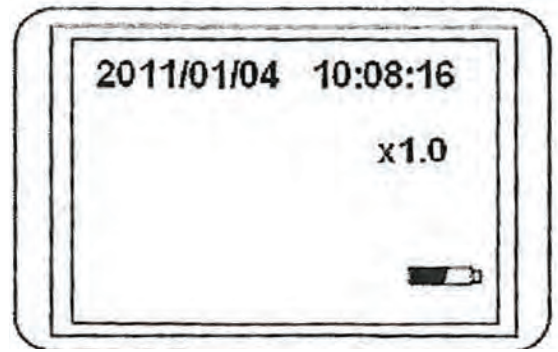

FIGURE 3 STATUS SCREEN

The status screen shows the capacity of the SD card and the internal battery. If the display has been stored for sometime the battery may need to be charged before use.

Use the power adapter to recharge the battery. Suggested 3-5 hours to fully charge.

A live image can be seen after the unit turns on, this is camera mode. It is strongly advised to properly setup the display before first use. Such as, Date and Time. The indexing of photos and video is based on the date and time only. Press the Power button. for 3-5 seconds to turn off.

3. MENU SETUP

- Switch the unit on. Ensure the status screen shows up briefly and clock is running.
- Press the OK button to access the menus. Use the UP or DOWN button to select the menu item.
- Press OK to confirm.

THE OPTIONS DISPLAYED IN THE MENU ARE AS FOLLOWS;

- DELETE ALL
- VIDEO OUTPUT
- DATE / TIME SETUP
- LANGUAGE
- VIDEO FORMAT
- AUTO POWER OFF
- LOCATOR TX
- LENGTH MEASURE
- TEXT ANNOTATION

Delete All

This option deletes all images and video from the SD card So be careful.

Navigate to DELETE ALL on the menu, press the OK button. Select YES or NO using the UP or DOWN buttons. Confirm with the OK button.

4. VIDEO OUTPUT

This function allows live shots, recorded photos and videos to be displayed to TV screen. First make sure that the Video format is set correctly to the TV system in use, (PAL or NTSC, in the menu setup section).

Connect the scope video cable to the display unit 1V video out Press the OK button to select menu options, select Video Output and press the OK button.

The scope unit screen will turn black and the display will switch to the TV. You can switch the screen back to the display by selecting the same Video Format Menu.

Press the PHOTO button to increase the value and the REC button to decrease the value. The date and time can be displayed in the preview image mode. Use either the REC or PHOTO button to toggle between display "ON and OFF" Confirm selection and exit menu by pressing OK.

DATE / TIME SETUP

Press the Up/Down button to select Year, Month, Day or Hours, Minutes, Seconds. Press OK and ESC to exit.

LANGUAGE

Navigate to LANGUAGE in the menu, press the OK button. Select the desired language using the UP & DOWN buttons and confirm with the OK button.

MENU
DELETE ALL
VIDEO OUTPUT
DATE/TIME SETUP
LANGUAGE
VIDEO FORMAT

TIME / DATE
2009/01/01
10:22:22
DISPLAY OFF

MENU
DELETE ALL
VIDEO OUTPUT
DATE/TIME SETUP
LANGUAGE
VIDEO FORMAT

AUTO POWER OFF

Navigate to AUTO POWER OFF in the menu, press the OK button. Select the desired Auto power off time (5,15,30 minutes or DISABLE) using the UP DOWN buttons, confirm with the OK button.

MENU
VIDEO OUTPUT
DATE / TIME SETUP
LANGUAGE
VIDEO FORMAT
AUTO POWER OFF

LOCATOR TX

Navigate to the MENU go to TX and press the OK button to confirm. The transmitter is now active for 512 HZ, there is an indicator on the screen.

MENU
DATE / TIME SETUP
LANGUAGE
VIDEO FORMAT
AUTO POWER OFF
LOCATOR TX

LOCATOR TX
TX OFF
TX ON

5. TEXT ANNOTATION

Navigate to TEXT ANNOTATION in the menu, press the OK button. Select and press EDIT TEXT to bring up the software keyboard and EDIT TEXT window. Move the orange square to the letter, number or symbol to select what you want. To key in, press the ENTER button to confirm. When finished select the save button, or long press the ENTER button for 3-4 seconds to save the entered text.

MENU	TEXT ANNOTATION
LANGUAGE	EDIT TEXT
VIDEO FORMAT	HD SCOPE
AUTO POWER OFF	TEXT COLOR
INPUT SOURCE	ON/OFF
TEXT ANNOTATION	

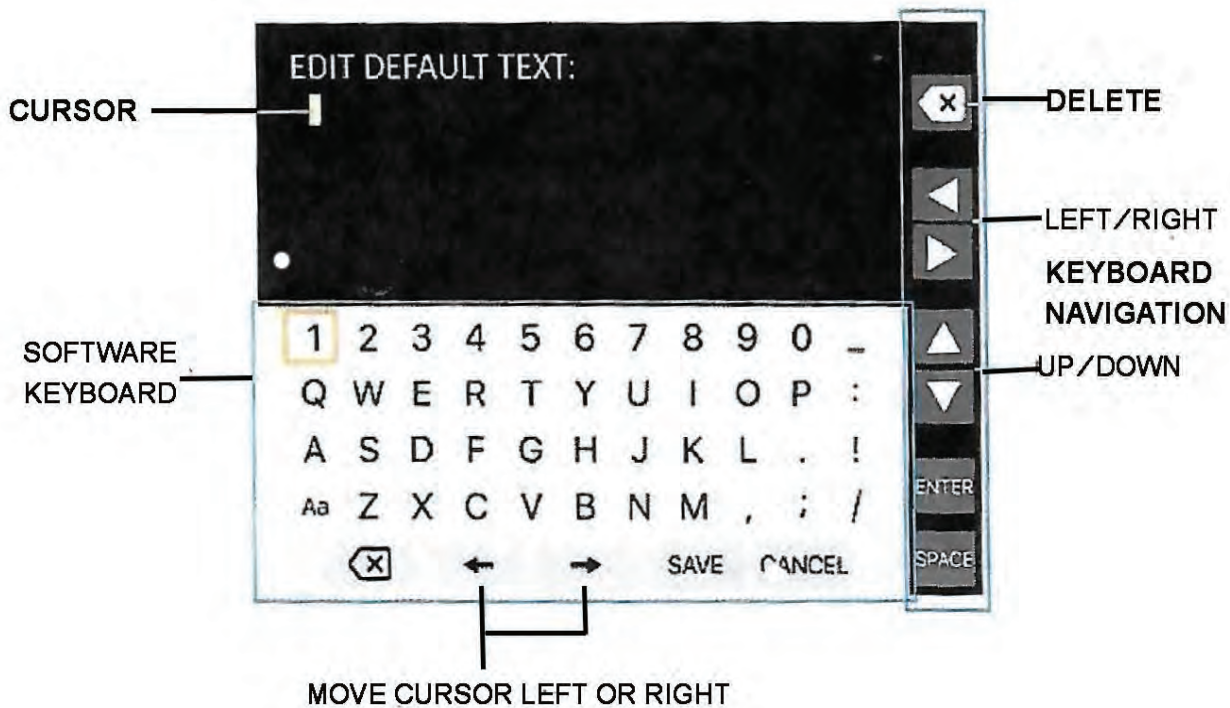

When selecting TEXT COLOR and pressing OK, user can choose either green, yellow or white as the color.

When selecting ON /OFF and selecting OK, user can choose to enable or disable the TEXT Annotation function.

6. DIGITAL ZOOM

The picture in preview mode can be modified by pressing the ZOOM in button and ZOOM out button for back to normal.



7. LED ADJUSTMENT

The LED brightness button is located on the buttons to the right of the screen. User is able to adjust the LED camera lights to suit conditions. The top button increases brightness while the bottom button dims the LED's.

8. IMAGE ROTATION

When pressing the  button the image will be rotated 90°, each successive push of the button will rotate the image 90°.

9. SNAPSHOT AND RECORDING

SNAPSHOT

In Camera mode press the PHOTO button to take a photo. The photo is saved to the SD card with the .JPG format with the file name in running order.

For example "IMG0001.JPG". Users can capture the picture they want during the video recording AND replay by pushing the PHOTO button. "

RECORDING

In Camera mode, press the REC button to take a video. The video icon is shown in the top right corner. To stop recording press the REC button again. The video icon disappears. The display reverts to preview mode. The video is automatically stored to the SD card in ASF format with the file name in running order. For example "IMG0001.ASF".

SNAPSHOT WHILE RECORDING

SWR function allows users to take a photo snapshot while recording, or playing back video, so you never miss an important shot.

10. FILE MODE

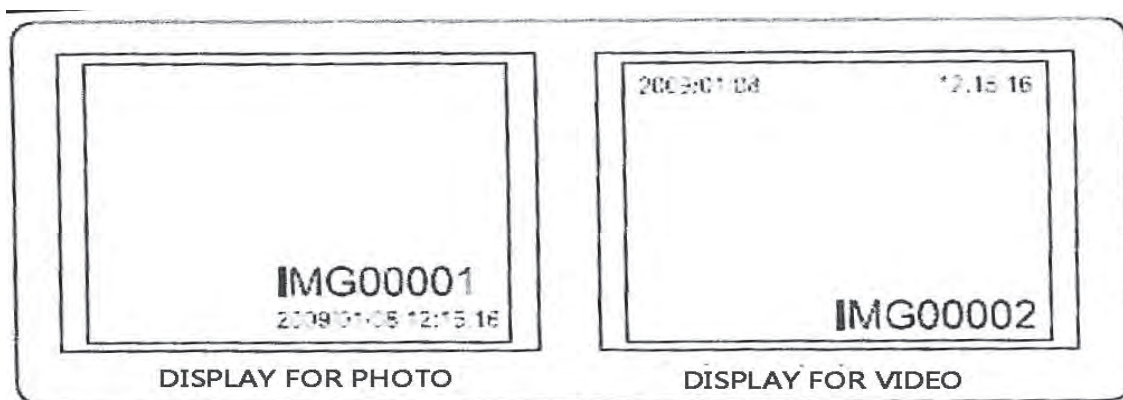

In the camera mode, press the UP or DOWN button, the last photo will be displayed. Press the UP or DOWN buttons to navigate to the photo or video to be viewed.



To play selected video press the REC button. To revert to preview mode, press the ESC button. To delete a saved photo, press the OK button while it is displayed. To delete a saved video, make sure the video is not in play mode, press the OK button, a delete menu will show. Toggle between the YES and NO options using the UP DOWN buttons. Press the OK button to confirm.

11. PHOTO COMPARE FUNCTION

A built-in photo compare function compares two photos on screen at the same time. Allows user to see differences on site without using computer software.

In the surfing menu press  to select first photo, press UP/DOWN buttons again to find the second photo and press , to start compare press  button.

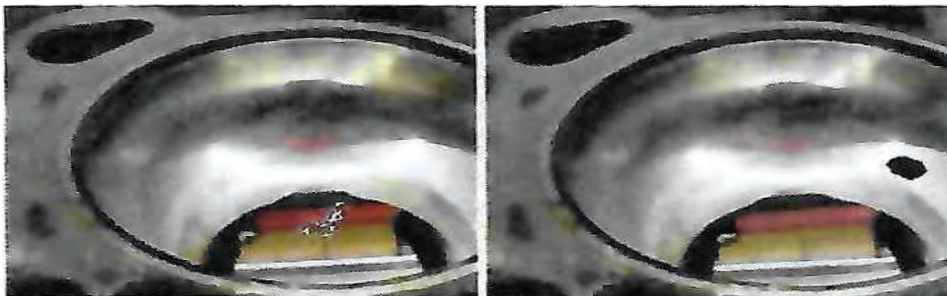

12. TRANSFERRING VIDEOS AND PHOTOS TO A PC

The computer must be running MS Windows 2000™ or later. Turn the unit on, connect the USB cable to the display unit and to the computer. Look for the drive with the SD card files, this should look similar to the following figure:



The files can then be transferred and viewed on a media player. JPG and ASF files should display without any special software.

13. TROUBLESHOOTING

- **No image on screen after powering on?**

Battery is exhausted, connect the unit to the supplied AC adapter and connect to charge the battery. The unit can be operated while on AC power.

- **No image, only words on the LCD display after turning power on.**

Check that the INTERFACE CORD is securely attached to the Display and at the cart side.

- **Unable to take photos or record video?**

SD card is not present or improperly inserted, full or faulty. Be sure it clicks into place. Check that SD card is present and not full and works in other devices.

- **How to reset the unit?**

If all functions freeze or fail, insert an insulated needle or dull ended object into the hole in the left side of the Display unit. Hold for 3-5 seconds and release. The system will restart automatically.

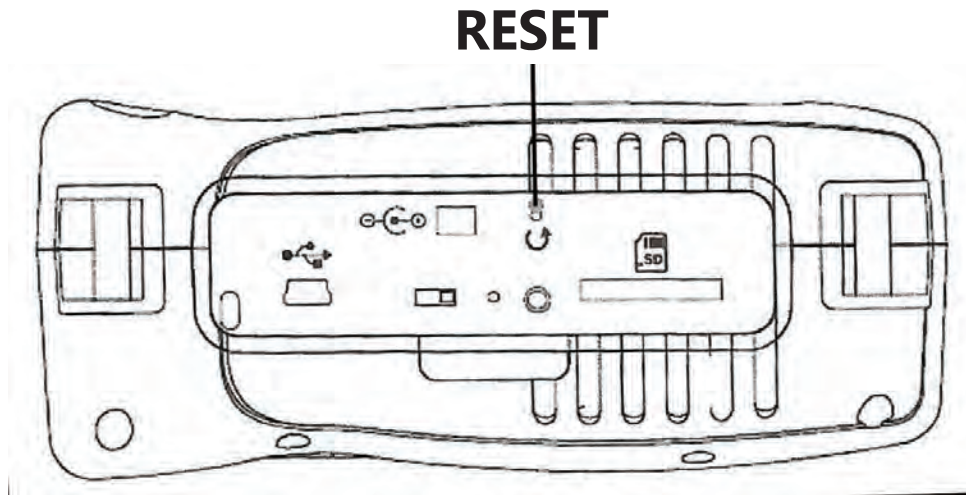

14. TECHNICAL DATA

Power Adapter	100~ 240V AC in /5V DC out
Display	7" 720x480 pixels color LCD TFT monitor
Interface	Mini USB 1.1; AV out
Battery (not user serviceable)	Rechargeable Li-Polymer battery 7.6Ah / 3.7V
Video Out Format	NTSC or PAL
Storage	SD card (up to 32GB)
Compression Format	MEPG4
Still Image Storage Format	JPEG (640x480)
Video Recording Format	ASF (640x480)
Working Temp.	-20° to 60°C (-4F to 40°F)
Battery Charging Temp.	0° to 40°C (32° to 104°F)
Recommended Storage Temp.	15° to 25°C (59° to 77°F)
Weight (Display only)	1.3Kg (2.86Lb)

15. REMOVAL OF REEL

Remove the push cable from the connector. Loosen the collar on the connector and pull the connector and the cable apart, being careful not to damage the pins. **FIG. 8**

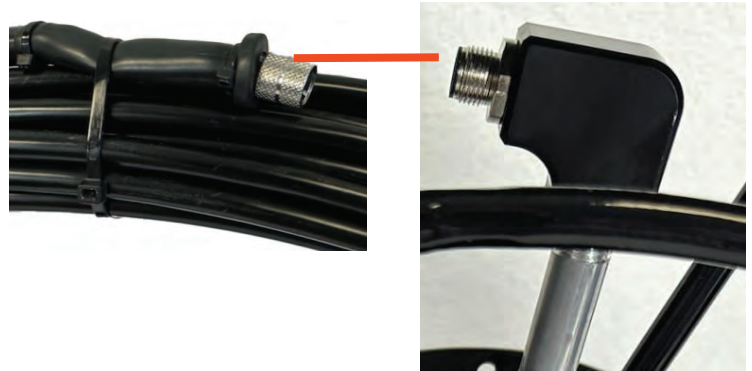

Fig. 8

Remove the 6 screws in the center of the reel. Carefully pull the reel out while securing the cart. **Fig. 9**



Fig. 9

The cart with reel removed.

Fig. 10

Hub remains attached to cart.
For hub removal see **Fig. 13**



FIG. 10

16. REMOVAL OF HUB FROM CART

Remove the interface cable from the connector on the hub (center of reel), loosen the collar then pull the connector out being careful not to damage any pins. **Fig. 11**



Fig. 11

Remove the push cable from the connector. Loosen the collar on the connector then pull the connector and the cable apart, being careful not to damage the pins. **Fig. 12**

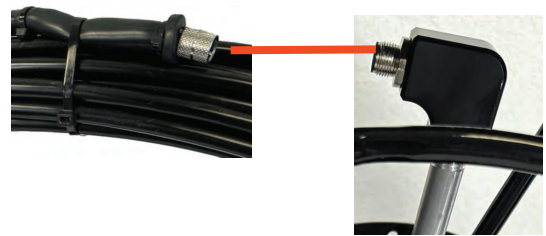
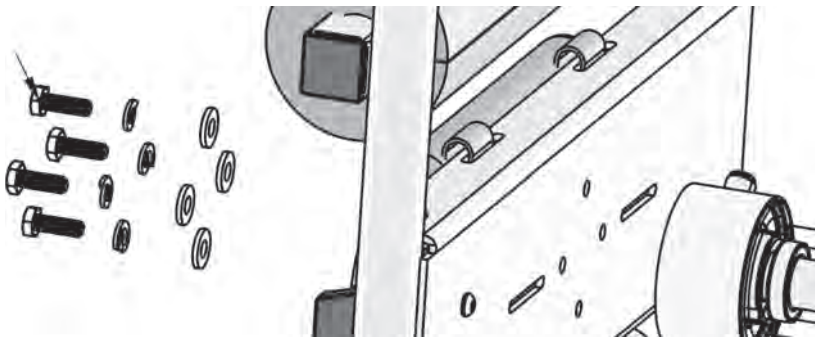

Fig. 12

Remove the 4 bolts from the rear of the cart to remove the hub. **Fig. 13**



ZOOM OF FIG. 13

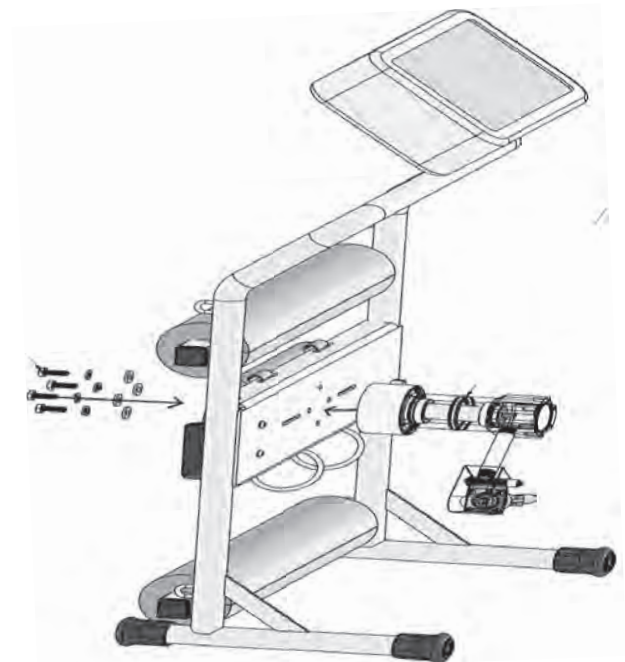

FIG. 13

17. ATTACH REEL

Align the reel over the hub shaft, note cutout in reel. Attach the 6 washers and screws.

Fig. 14

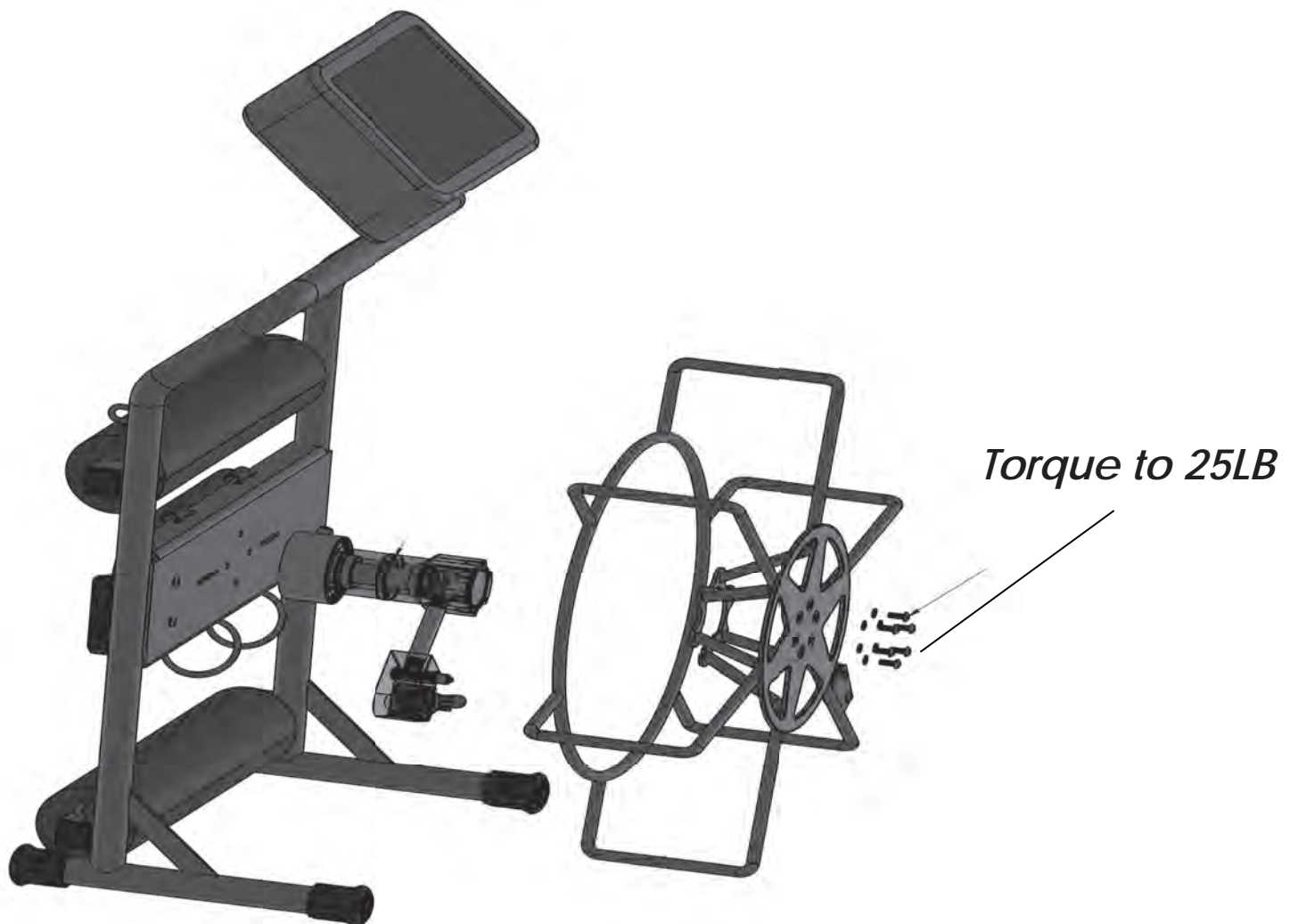

FIG.14

18. Remove / Install Camera

Using an allen wrench remove the set-screw #7 **FIG 16**. Unscrew the collar from the cable at camera. Pull straight out being careful not to bend the pins. To reattach be sure top screw on the camera aligns with cutout on connector **FIG. 15** and push together until firmly connected, tighten collar and place set screw to secure. **FIG. 16**

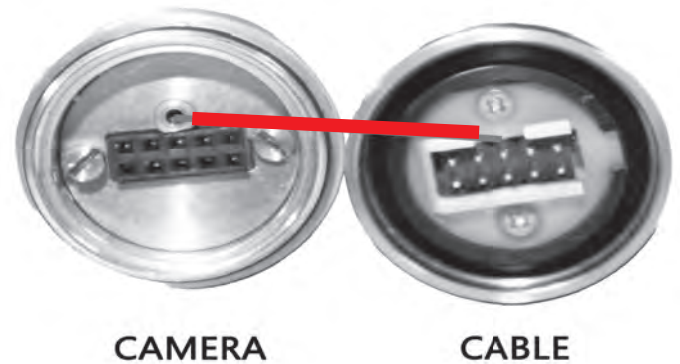

FIG. 15

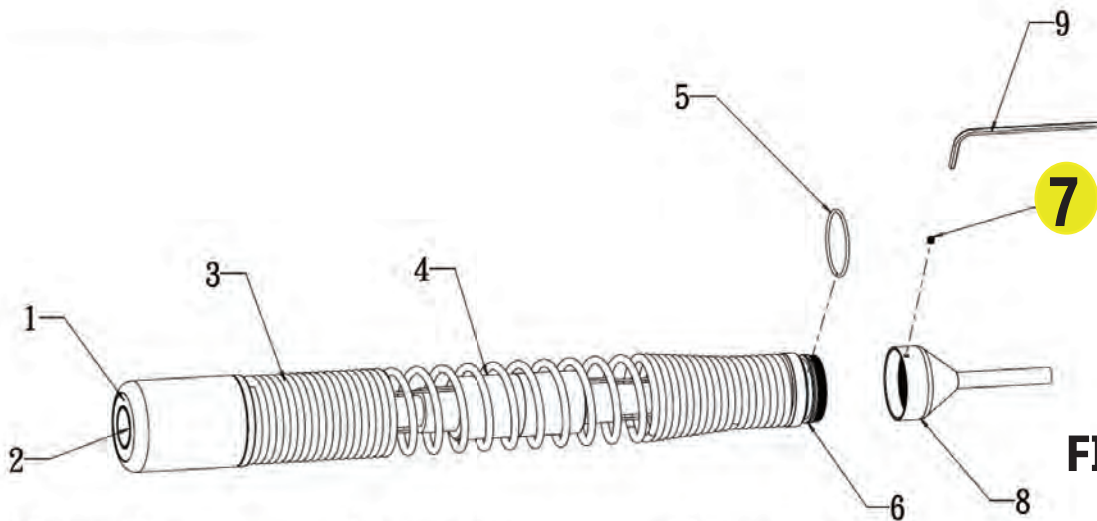

FIG. 16

- | | | |
|-----------------------|-----------------------------|-----------------------------|
| (1) Camera LEDs | (2) Camera Lens | (3) Cover Spring |
| (4) 512Hz Transmitter | (5) O-ring | (6) O-ring Slot and Threads |
| (7) Setting Screw | (8) Push Rod Thread Coupler | (9) Hex Wrench |

Note: The camera LEDs become warm when set to maximum intensity.

Warnings

- Keep the connector dry and clean when dis-attach or attach the camera to the coupler
- Warranty is invalid if stickers, tags, or labels are removed

#7 THE SET SCREW IS VERY SMALL!

USE CAUTION WHEN HANDLING.

Small allen head.

19. SKID INSTALLATION

For single piece skids.

Loosen set screws being careful not to pull them out.

Slide skid over camera head, push on fully.

Tighten set screws

Tug lightly on skid to be sure it is tight. **FIG. 17**



FIG. 17

20. WIFI

The display has a WIFI function to mirror to a phone or tablet.

1. Go to WIFI in settings on phone or tablet and connect to the network SUBTECH-XXXX. The password is 12345678, if you click remember this network you shouldn't need the password on future uses.
2. After successfully connecting, on the phone or tablet open browser and type in `http://10.10.10.254/`
3. Login into website with username of **admin** and password of **admin** to gain access of the control panel.
4. After initial setup the steps 2 and 3 may be skipped and enter-
`http://10.10.10.254:8080/` for the live image without going through setup. See **FIG. 18**

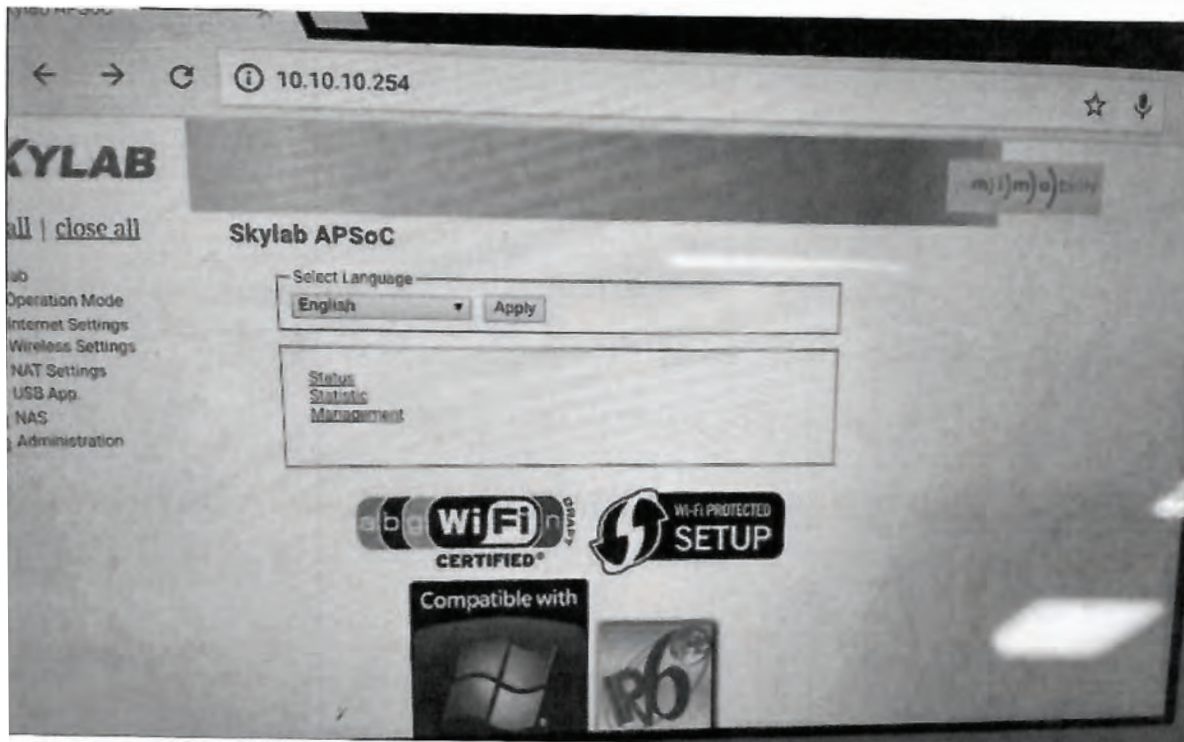

FIG. 18

21. Camera Locators

This system is equipped with a 512 Hz receiver to locate the camera head.

We offer two locators. The traditional VM-540 is a stick locator and uses sound to notify the user.

The V-loc3 uses a visual interface to guide the user to the camera as well as sound.



VM-540



V-LOC3

22. SPECIFICATIONS

Model Specifications

- **Line Capacity: 1"–4"**
- **Max. Distance: 180 ft (54.9 m)**
- **Operating Depth: 350 ft. (150 psi)**
- **Display: 7" 720(H) x 480(V) Pixels Color LCD TAFT Monitor**
- **Rechargeable Battery**
- **Camera Dimensions: 1.3" x 2" (33 mm x 50.8 mm)**
- **Push-Rod Diameter: 0.394" (10mm)**
- **Video Format: NTSC or PAL**
- **Interface~ Mini USB 1.1; AV Out**
- **Power: 100–240V AC in/5V DC Out**
- **Operating Temperature: -4°–140°F**
- **Weight: 29lb**

Available Options

- **Camera Locator Receiver**
- **18V Milwaukee Battery System**

Subtech Vision Technology Limited

Warranty

WARRANTY COVERAGE

Subtech Vision Technology, Inc. ("Subtech") warrants this hardware product against defects in materials and workmanship for a period of ONE (1) YEAR from the date of original purchase for our Camera Systems, Leak Detectors, and Locators, and THIRTY (30) DAYS from the date of original purchase for our Media Recording Devices (USB Recorder etc.). If a defect exists, at its option Subtech will repair the product at no charge, using new or refurbished replacement parts, or exchange the product with a product that is new or which has been manufactured from new or serviceable used parts and is at least functionally equivalent to the original product. A replacement product/part assumes the remaining warranty of the original product or ninety (90) days from the date of replacement or repair, and the replaced item becomes Subtech's property.

Push cables (also referred to as **pushrods**) are **NOT** warranted against damage of any kind, including but not limited to breaks, kinks, deformation, or wear, regardless of cause. Such damage is considered the result of operational conditions and usage outside the scope of warranty coverage.

OBTAINING WARRANTY SERVICE

Please contact Subtech directly (contact information provided below) to arrange for repairs. Generally, the unit will need to be delivered to either Subtech or one of our Repair Centers for repair work. When you contact Subtech, you will be asked to furnish your name, address, telephone number, and proof of the original purchase (receipt), model and serial number of the product, and description of the problem. You will be advised of where the unit needs to be sent for repair.

EXCLUSIONS AND LIMITATIONS

This Limited Warranty applies only to products manufactured by or for Subtech. This Warranty does not apply:

- (a) to damage caused by accident, abuse, misuse, misapplication, or non-Subtech Products;
- (b) to damage caused by service performed by anyone who is not an authorized Subtech Repair Center;
- (c) to a product or a part that has been modified without the written permission of Subtech;
- (d) if any Subtech serial number has been removed or defaced;
- (e) to damage or failure of push cables (pushrods), including but not limited to breaks, kinks, or deformation, regardless of cause.

Using an **A/C adapter other** than the original or a replacement **NOT** purchased through Subtech **WILL void** the warranty and may cause major system damage!

THIS WARRANTY AND REMEDIES SET FORTH ABOVE ARE EXCLUSIVE AND IN LIEU OF ALL OTHER WARRANTIES, REMEDIES AND CONDITIONS, WHETHER ORAL OR WRITTEN, EXPRESS OR IMPLIED. SUBTECH SPECIFICALLY DISCLAIMS ANY AND ALL IMPLIED WARRANTIES, INCLUDING, WITHOUT LIMITATION, WARRANTIES OF MERCHANTABILITY AND FITNESS FOR A PARTICULAR PURPOSE. IF SUBTECH CANNOT LAWFULLY DISCLAIM IMPLIED WARRANTIES UNDER THIS LIMITED WARRANTY, ALL SUCH WARRANTIES ARE LIMITED IN DURATION TO THE DURATION OF THIS WARRANTY.

No Subtech reseller, agent, or employee is authorized to make any modification, extension, or addition to this warranty.

SUBTECH IS NOT RESPONSIBLE FOR DIRECT, SPECIAL, INCIDENTAL OR CONSEQUENTIAL DAMAGES RESULTING FROM ANY BREACH OF WARRANTY OR CONDITION, OR UNDER ANY OTHER LEGAL THEORY, INCLUDING BUT NOT LIMITED TO LOST PROFITS, DOWNTIME, GOODWILL, DAMAGE TO OR REPLACEMENT OF EQUIPMENT AND PROPERTY.

Some states do not allow the exclusion or limitation of incidental or consequential damages or exclusions or limitations on the duration of implied warranties or conditions, so the above limitations or exclusions may not apply to you. This warranty gives you specific legal rights, and you may also have other rights that vary by state.

Please keep on file or in a safe place with your original receipt for warranty purposes.

Date of purchase: _____

Serial Number(s): _____

For warranty repair requests or to find the location of your nearest authorized Repair Center, please call Subtech at (877) 754-3435 or (209) 531-9716.

SERVICE & REPAIR

For service or repair, the unit should be returned to an authorized repair center or our factory. To minimize downtime, we stock critical components for The Junior and can ship quickly when field replacement is possible.

THE JUNIOR FEATURES FIELD-REPLACEABLE COMPONENTS.

LESS DOWNTIME. MORE TIME ON THE JOB.

Repair Department

Subtech Manufacturing Inc.

2905 Railroad Avenue Ste. A

Ceres, CA 95307

WWW.SUBTECHMFG.COM

Phone: 877-754-3435

Technical Support: 209-269-3251

Office: 209-531-9716